

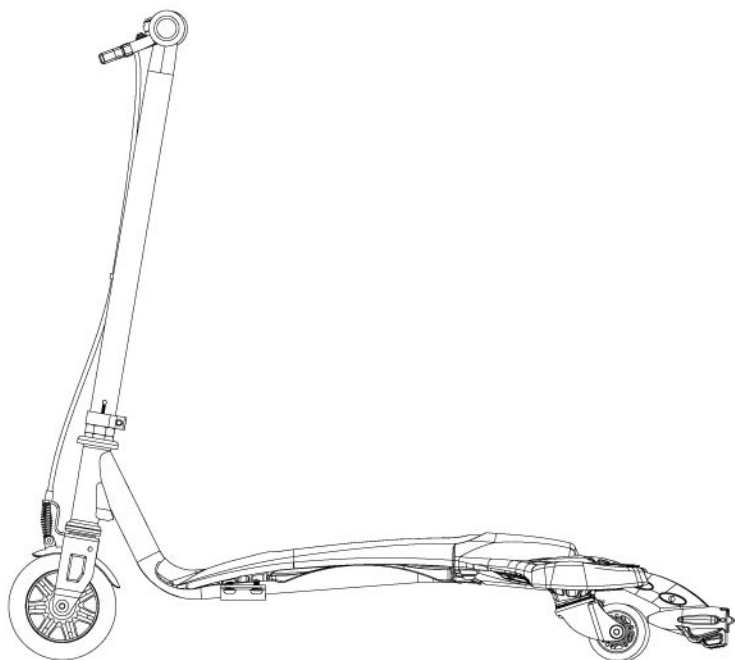

Owner's Manual

EN



COOL CARVER -1

Read and save this instruction manual before allowing your child to use this product !

Model Number: XF126

EN71 PART3. PHTHALATE APPROVAL.

Maximum rider weight: 50 kgs (110 LBS).

Not suitable for children under 5 years old.

1. SAFETY WARNINGS



AN IMPORTANT MESSAGE TO PARENTS:

This manual contains important safety information. For your child's safety, it is your responsibility to review this information with your child and make sure that your child understands all warnings, cautions, instructions and safety topics. JDBug recommends that you periodically review and reinforce the information in this manual with younger riders. You should also regularly inspect and maintain your child's scooter to ensure their safety.



GENERAL WARNING:

Scooter riding can be a hazardous activity. Scooters can, and are intended to move and it is therefore possible to get into dangerous situations and/ or lose control and/ or fall. If such things occur you can be seriously injured or die.

LIKE ANY OTHER MOVING PRODUCT, USING A SCOOTER CAN BE A DANGEROUS ACTIVITY AND MAY RESULT IN INJURY OR DEATH EVEN WHEN USED WITH PROPER SAFETY PRECAUTIONS. USE AT YOUR OWN RISK AND USE COMMON SENSE.

- Always wear proper protective equipment, such as an approved safety helmet, elbow pads, knee pads and lace-up athletic shoes are recommended. Don't ride barefoot or in sandals. Keep shoelaces out of the way of wheels.
- Ride the scooter only on smooth, paved surfaces away from motor vehicles.
- Never ride the scooter at dusk or night or in wet or icy conditions.
- Avoid streets and surfaces with water, sand, gravel, dirt, leaves, sharp bumps, drainage grates and other debris, because surface changes may cause the scooter to suddenly stop, and wet weather impairs traction, braking and visibility.
- Remove all sharp edges caused during the use.
- Protective equipment should be worn.
- Do not exceed 50kgs (110 LBS) total weight on the scooter.
- Adults must assist children in the initial adjustment procedures to unfold scooter, adjust handlebar and steering to height, and finally to fold scooter.
- Do not allow children under age five (5) to use the scooter. All children and preteens should ride with adult guidance at all times.
- Brake will get hot from continuous use. Do not touch after braking. Do not remove the braking system.
- Please read the instruction and use the brake properly.
- Please do proper maintenance on bearings.
- After several times maintenance, bolts and nuts may be damaged and broken.
- Replace worn or broken parts immediately.



ACCEPTABLE RIDING PRACTICES AND CONDITIONS:

Direct parental supervision is required. Scooters are meant to be used only in controlled environments free of potential traffic hazards and not on public streets. Do not allow your child to ride a scooter in any areas where vehicle traffic is present. Rider must maintain a hold on the handlebars at all times by using both hands. Never allow more than one child at a time to ride a scooter. Never use near steps, sloped driveways, hills, roadways, alleys or swimming pool areas. Keep fingers and other body parts away from the product when folding or unfolding. Adults must not allow children to assist in folding or unfolding the scooter.

FAILURE TO USE COMMON SENSE AND HEED THE ABOVE WARNINGS FURTHER INCREASES RISK OF SERIOUS INJURY. USE AT YOUR OWN RISK AND WITH APPROPRIATE AND SERIOUS ATTENTION TO SAFE OPERATION.

 **WARNING:**

DO NOT USE NON-JDBug PRODUCTS WITH YOUR JDBug SCOOTER. Your scooter has been built to JDBug design specifications. All the original equipments supplied at the time of sale were selected on the basis of their compatibility with the frame, fork and all other parts. Certain after market products may or may not be compatible with your JDBug Scooter. Unsuitable modification can be hazardous! Consult your retailer or call JDBug prior to modifying or replacing any component with a non-factory specified product.

 **WARNING:**

CHECK LOCAL LAWS REGARDING SCOOTER USE. Check local laws and regulations to see where and how you may use your JDBug scooter legally. Check local laws and regulations governing helmet use and scooter operation in your area.

USE CAUTION

 **WARNING:**

ALWAYS INSPECT SCOOTER PRIOR TO RIDING. Properly inspecting and maintaining your scooter can reduce the risk of injury. Always inspect your scooter before riding and regularly maintain it.

2. SCOOTER PARTS AND COMPONENTS

- Estimated Assembly and Set-up Time about 5 minutes.

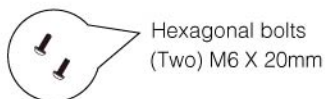
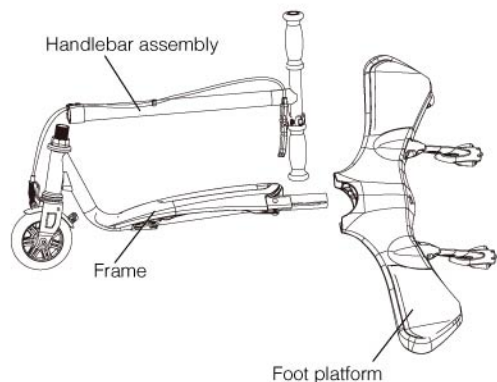

- Required Tools
Tools needed to assemble are included.



(One) 5mm Allen wrench
(included)

3. ASSEMBLY INSTRUCTIONS



- ① Position the foot platform up to the frame and align the holes. Using the 5mm Allen wrench to tighten (Two) M6 X 20mm hexagonal bolts properly until the foot platform and frame is secure.



- ② Insert the handlebar stem into the front fork. Using the 5mm Allen wrench to tighten the hexagonal bolts until the handlebar is secure.

■ Adjusting the Brake

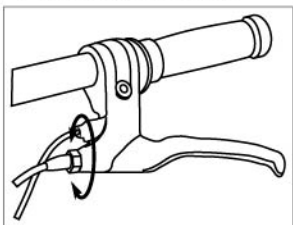

To adjust the brake cable wire, thread the brake lever adjuster in or out 1/4 to 1/2 turn until the desired cable tension is attained.

WARNING:

Failure to properly tighten the wedge may allow the handlebars to dislodge while riding and may cause you to lose control and fall. When correctly tightened, the handlebars will not rotate out of alignment with the front wheel under normal circumstances.

Note: When self-locking nuts and other self-locking fixings may lose their effectiveness.

■ Replacing the Wheels and Bearings

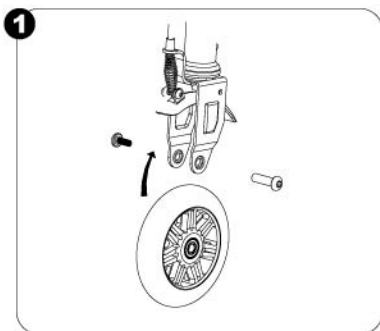

Front wheel sequence.

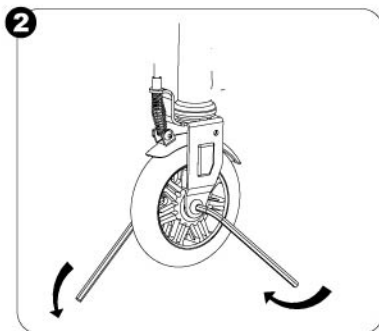

Securely tighten the bolt as shown.

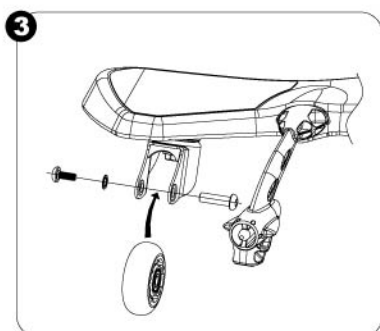

Rear wheel sequence.

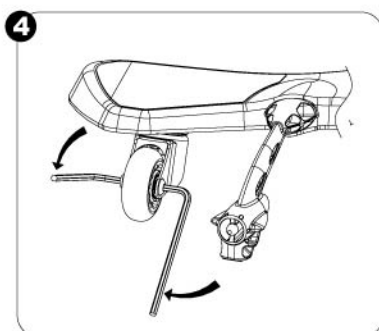

Securely tighten the bolt as shown.

4. CLEANING YOUR SCOOTER

Wipe with a damp cloth to remove dirt and dust. Do not use industrial cleaners or solvents as they may damage the surfaces. Do not use alcohol, alcohol-based or ammonia-based cleaners as they may damage or dissolve the plastic components or soften the decals or decal adhesive. Store the scooter in a dry, dust-free place.

5. WHEELS AND BEARINGS

Under normal circumstances and conditions, the wheels and the bearings are maintenance free. Nonetheless, it is the responsibility of the owner or guardian to periodically inspect the wheels for wear and tear, the axle for proper tightness and bearings for side-to-side play and loose parts. When a wheel or wheel bearing develops play, this is an indication of excess wear and replacement is necessary. Replace immediately with only JDBug wheels. Worn wheels / bearings are considered normal wear-and-tear and are not covered by the JDBug Warranty. Wheels other than JDBug wheels may not be compatible with your JDBug scooter. The use of anything other than JDBug replacement parts may affect your safety and will void your warranty.

6. COOL CARVER PARTS

- 01 Handlebar Stem
- 02 Handlebar Grip(2)
- 03 Brake Lever Assembly
- 04 Collar Clamp
- 05 Headseat
- 06 Front Fork with Fender
- 07 Brake Base
- 08 Coupling Bolt
- 09 Brake Spring
- 10 Coupling Bolt
- 11 Front Wheel Bearings
- 12 Front Wheel Spacer
- 13 120 mm Wheel
- 14 Foot Platform
- 15 Platform Cover (Right / Left)
- 16 Bolt
- 17 Stability Bar(Right/Left)
- 18 Caster
- 19 64 mm Rear Wheel

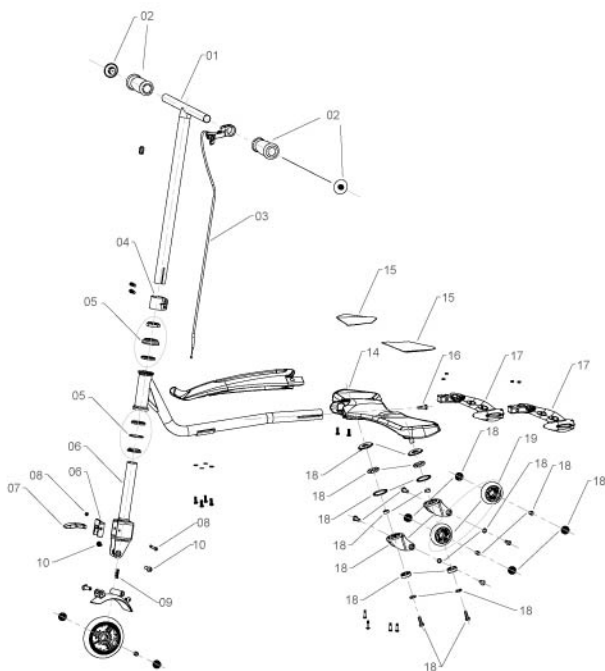

7. SAFETY REMINDERS

Loose Parts

Check and secure all fasteners before every ride. Make sure the steering bolts and foot steppers are tight. There should not be any unusual rattles or sounds from loose parts or broken components. If you are not sure, ask an experienced mechanic to check.

Brake

Check the brake for proper function. When you squeeze the lever, the brake should provide positive braking action.

Frame, Fork and Handlebars

Check for cracks or broken connections. Although broken frames are rare, it is possible for an aggressive rider to run into a curb or fall and wreck, bend or break a frame. Get into the habit of inspecting yours regularly.

Safety Gear

Always wear proper protective equipment such as an approved safety helmet, elbow pads and kneepads. Always wear shoes (lace-up shoes with rubber soles), never ride barefooted or in sandals, and keep shoelaces tied and out of the way of the wheels.

Be Careful!

You will see people you know on TV doing tricks and stunts. These are people who have been practicing on scooters for a very long time. Don't try something until you are ready. Avoid steep inclines and don't ride too fast – you might lose control and fall. Skateboard parks are not designed for scooters. Never ride in traffic or on the street and watch your surroundings for pedestrians, bikers, boarders and skaters.

8. LIMITED WARRANTY

This Limited Warranty is the only warranty for JDBug scooters. There is no other express or implied warranty. The manufacturer warrants this product to be free of manufacturing defects for a period of six months from date of purchase. This Limited Warranty does not cover normal wear and tear, nor any damage, failure or loss caused by improper assembly, maintenance, storage or use of the scooter.

This Limited Warranty will be void if the product is ever:

- a. Used in a manner other than for recreation or transportation:
- b. Modified in any way;
- c. Rented.

Check local laws and regulations to see where you may ride your scooter legally. The manufacturer is not liable for incidental or consequential loss or damage due directly or indirectly from the use of this product.

To obtain service under this warranty you must, within the warranty period, contact local distributor or by e-mail through JDBug website www.jdbug.com.

JDBug will provide warranty replacement at its sole discretion.

Specifications subject to change without notice.

